



## Architectural Review Manual

September 21, 2004  
(Updated on May 16, 2007)

# PINTAIL POINT

## Architectural Review Manual

### I. INTRODUCTION

- A. Purposes of An Architectural Review Board
- B. Architectural Design Concept
- C. Architectural Review Board Profile and Jurisdiction
- D. General Requirements
- E. Disclaimer

### II. APPROVAL PROCESS AND PROCEDURES

- A. Process Steps
- B. Explanation of Process Steps

### III. SITE PLANNING GUIDELINES / MINIMUM DESIGN STANDARDS

- A. Building Setbacks
- B. Site Clearing
- C. Site Grading
- D. Site Run Off
- E. Construction Trash
- F. Driveways and Garage Access
- G. Sidewalks
- H. Landscaping
- I. Signs
- J. Walls and Fences
- K. Decks/Docks
- L. HVAC Condenser
- M. Satellite Dishes
- N. Mailbox Posts
- O. Site Lighting

### IV. HOUSE PLANNING DESIGN GUIDELINES / MINIMUM DESIGN STANDARDS

- A. Size
- B. Foundations
- C. Foundations of 5' or More in Height
- D. Exterior Walls
- E. Windows
- F. Cornices
- G. Roof
- H. Porches
- I. Chimneys
- J. Accessory Structures

# PINTAIL POINT

## Architectural Review Manual

### I. INTRODUCTION

#### A. Purposes of An Architectural Review Board

The purposes of the Architectural Review Board are 1) to establish and to maintain the design harmony of Pintail Point and 2) to promote and protect the value of the properties within Pintail Point.

#### B. Architectural Design Concept

Pintail Point is envisioned as a premier single-family residential neighborhood featuring large wooded lots, with homes of exceptional architectural character positioned to maximize privacy and to create a sense of elegance and dignity. House designs should be traditional South Carolina architecture or a derivation thereof. Designs should appear indigenous and non-intrusive, embracing the surrounding wooded site, lake views, and natural surroundings. Each house should contribute its own unique qualities within the indigenous regional context. Design control, through the use of a strong Architectural Review Board, is seen as the way to create and to maintain the highest standards both for the realization of this vision and for maintaining the value of the investment being made here.

#### C. Architectural Review Board Profile and Jurisdiction

A declaration of Covenants and Restrictions for Pintail Point has been recorded at Lexington County. These Covenants and Restrictions establish specific standards for the ownership and use of property in Pintail Point.

The Covenants and Restrictions also create an Architectural Review Board with control vested in LAB Investors, LLC. The Architectural Review Board may establish rules, procedures, guidelines and reasonable fees as are necessary to achieve its purposes and objectives.

#### D. General Requirements

##### 1. Overview:

In order to create and maintain a high-level residential development, to assure that landscaping, houses and other structures are of appropriate size, color, and material, and are of harmonious design, properly located in relationship to neighboring structures and adapted to the terrain of each lot, the Declarant reserves the right of full architectural approval, including determination of the position of improvements on the lot, in order to achieve these objectives. Accordingly, no landscaping and no building, outbuilding, swimming pool, fence, wall, garage, driveway, deck, dock, walkway, or structure of any kind or alterations or additions thereto shall be erected or placed on any lot and no trees over four inches in diameter shall be cut until the complete plan, specifically proposed design and location thereof on the lot, shall have been submitted to the Declarant or a committee designated, in writing, by Declarant for approval and approval granted. The Declarant reserves the right to approve or disapprove proposed improvements for any reason. Such approval shall not be unreasonably withheld and shall be given or denied in writing within thirty (30) days of submission to the Declarant or its designated architectural committee.

## PINTAIL POINT

### Architectural Review Manual

#### 2. Vacant Lots:

Construction of a house (with plans approved by the ARB) shall commence within eighteen months after purchase of the lot. If construction has not started after eighteen months, the lot owner will be assessed the following fee to maintain the vacant lot:

\$1,000 for a lot of an acre or less

\$2,000 for a lot of more than an acre

After construction of a house is started, the owner can request that the fee be returned, minus expenses the developer has disbursed to maintain and/or clean the lot.

#### 3. Site Use:

No temporary structure, school bus, camper, motor home or mobile home, satellite dish or freestanding antenna, or temporary structure of any kind shall be erected, kept had or allowed at any time on any lot hereby conveyed; provided, however, that a camper or motor home may be parked in an enclosed garage, provided such garage meets all requirements for buildings and improvements contained elsewhere in these restrictions. All rubbish, garbage and trash shall be kept in closed cans or other suitable containers, which shall be placed and kept behind the house, out of sight from the street or neighbors' houses and maintained in an enclosed area approved in writing by Grantor. No clothesline shall be allowed. The lot, property and premises shall be kept clean at all times. Boats may be kept on the property provided they are kept in the garage. Boats, boat trailers, and utility trailers may temporarily be parked in the driveway for two consecutive nights, but shall be removed before the third night. Unused automobiles, miscellaneous sporting equipment, and other such items are not to be stored in driveways or yards where visible from the street or neighbors' yards. No construction materials or similar items shall be stored in yards or driveways where visible from the street or neighbor's yards except when such items are related to an ongoing construction project. Such material shall be removed promptly at the completion of construction. Utility structures such as permanent propane tanks must be buried or hidden from general view.

**PINTAIL POINT**  
**Architectural Review Manual**

E. Disclaimer

The above standards and procedures are subject to change by the A.R.B. at any time, and from time to time. The A.R.B. may use its collective discretion and judgment in regard to the interpretation of the above standards, as it deems appropriate for the best interest of Pintail Point and its residents.

No approval of plans, location or specifications by the A.R.B. and no publication of architectural standards or guidelines shall be construed as representing or implying that such plans, specifications or standards will, if followed, result in a properly designed or constructed residence.

**II. APPROVAL PROCESS AND PROCEDURES**

A. Process Steps

In order to provide a uniform and systematic review procedure of all proposed designs, plans, and construction in Pintail Point, the following sequence has been established.

1. Application and Payment of Review Fee
2. Preliminary Design Review and Approval
3. Final Drawings Review and Approval
4. Periodic Inspection During Construction
5. Final Inspection Upon Completion of Construction
6. Landscape Plan Review and Approval
7. Future Improvement Review

B. Explanation of Process Steps

1. Application Submittal and Payment of Review Fee

A Design Review application form must be completed and submitted by the property owner or the owner's agent to the Architectural Review Board before the commencement of any construction activity of any type. This application must be accompanied by payment in full of the appropriate nonrefundable Submission Fee as outlined below:

- a. Single Family Residence.....\$ 500.00
- b. Additions and Renovations..... \$ 500.00
- c. Pools, Decks, Fences and Enclosures..... \$ 100.00  
(No charge if included with a. or b. submittal)
- d. Landscaping & Irrigation..... \$ 100.00

NOTE: The above fees are subject to change without prior notice. The owner or agent should include with the application and fee all documents and other information which are outlined under the Preliminary Design Review requirements as hereafter specified and deliver to the Architectural Review Board, c/o Molten/Lamar Architects, 808-C Lady Street, Columbia, South Carolina 29201.

# PINTAIL POINT

## Architectural Review Manual

### 2. Preliminary Design Review and Approval

Prior to the completed design of improvements, a preliminary review of the owner's plans shall be conducted to determine compliance with the design requirements of the Architectural Review Board, as well as to provide further design recommendations if needed.

The owner or agent should furnish a complete set of the following documents and information together with the application and fee.

#### a. Site Plan, drawn to a scale not smaller than 1" = 20' showing:

- 1) Owner's name.
- 2) North arrow and scale.
- 3) Property lines with dimensions and bearings.
- 4) Elevations of lot corners, center of lot, edge of roadways and lake edge, water level and top of bank location if applicable.
- 5) Setback limits.
- 6) Complete tree survey noting all trees over 6" in diameter at 4' height from grade. (Note tree size and species.) Trees to be removed or endangered by construction to be so noted.
- 7) Preliminary grading plan showing existing and proposed contours. (On lots with more difficult grade, a more extensive grading plan showing proposed culvert locations, inverts and flow directions, cut/fill requirements, retaining walls, berm locations and heights may be required.)
- 8) Preliminary conceptual landscaping plan.
- 9) Access to street, drives, parking area, walks, decks and patios with elevations indicated.
- 10) Building accurately located from property lines and setback lines.
- 11) Dwelling to be indicated as exterior walls with entry area and stairs delineated and roof and deck lines shown.

#### b. Elevation drawings showing:

- 1) All four elevations.
- 2) Scale 1/4" - 1'.
- 3) Relation of building to grade level.
- 4) Floor elevations, ceiling heights, and window head heights.
- 5) Overall height from grade to ridge of roof.
- 6) Description of all exterior materials, roof materials and colors to be used.

NOTE: The Architectural Review Board encourages applicants to submit any color renderings or scale models which may be available.

# PINTAIL POINT

## Architectural Review Manual

- c. Floor Plan drawings showing:
- 1) Each floor plan.
  - 2) Scale 1/4" = 1' = 1'-0".
  - 3) Overall dimensions.
  - 4) Square footage area of structure (List heated and unheated areas separately).
  - 5) Room use labeled.
  - 6) All walls, windows and exterior doors.
  - 7) All overhangs of floors or roofs.
  - 8) Ground level plan to show foundations, enclosure, driveway location, stairway, garbage and HVAC equipment locations.
  - 9) Roof plan.

The results of the Architectural Review Board action will be forwarded to the applicant as soon as possible. If a substantive restudy is required, the applicant may elect to submit plans again for Preliminary Review before proceeding with the preparation of final working drawings.

### 3. Final Drawings Review and Approval

A complete set of the following information in addition to that required for Preliminary Design approval is to be submitted to the Architectural Review Board to be considered for final approval.

The following information is to be submitted:

- a. Final site plan
- b. Final grading plan
- c. Final floor plans and elevations
- d. Plans for ancillary detached structures showing quality and standard of materials
- e. Exterior lighting plan
- f. Final construction specifications
- g. Sample materials and colors of exterior components
- h. Proposed construction schedule
- i. Sections:
  - 1) Typical wall from grade to roof
  - 2) Typical decks and railings
  - 3) Typical foundation screen detail
  - 4) Typical screened porch
  - 5) Typical service yard fence or screening detail

Please note that the exterior of all houses and other structures must be completed within one (1) year after the approval of the plans by the ARB has been granted, except where such completion is impossible or would result in great hardship to the owner or builder due to strikes, fires, national emergency or natural calamities as determined by the Architectural Review Board.

# PINTAIL POINT

## Architectural Review Manual

Plans submitted for review, or any portion thereof, may be disapproved upon any grounds which are consistent with the purposes and objectives of the Architectural Review Board, including purely aesthetic considerations.

Upon final review and approval by the Architectural Review Board, an approved design review form will be forwarded to the applicant to be signed by the owner and a representative of the Architectural Review Board. The form of this agreement may be found in the forms section of this manual.

When fully executed, the Design Review Form agreement shall serve as final approval by the Architectural Review Board for the construction of the improvements. If construction has not commenced within six (6) months after the date of the Final Approval agreement, it shall be deemed to have expired unless the applicant, prior to such expiration date, has requested an extension in writing from the Architectural Review Board.

### 5. Periodic Inspections During Construction

The right of entry and inspection is specifically reserved by the Architectural Review Board, its agents and representatives to visit all or any portion of the owner's property for the purpose of verifying compliance with the requirements of the Board, and a representative of the Architectural Review Board will make periodic inspections without notice during the entire construction period. The owner will be notified in writing to the general contractor of any items and exceptions noted in the inspection report and all such items and exceptions must be accomplished or resolved promptly.

### 6. Final Inspection Upon Completion of Construction

The applicant shall notify the Architectural Review Board when the construction is substantially complete, and a representative of the Board will make a final inspection. Upon approval of construction, the Architectural Review Board will issue a final inspection certificate to the Lexington County Building Inspector and request that he conduct his final inspection and issue a Certificate of Occupancy.

### 7. Landscape Plan Review and Approval

In order to assure all residents of Pintail Point that the community will continue to be an attractive and scenic place to reside, the Architectural Review Board requires that each property owner constructing a new dwelling, or wishing to change their present landscape scheme, submit a Landscape and Irrigation Plan to the Board for review and approval. The plan should include the following:

- a. Preferred scale of 1" = 20'
- b. Variety, size, number and location of all plant material
- c. Type and description of seeded areas
- d. Plant list with quantity, botanical name, common name, size and special specifications
- e. Irrigation or sprinkler plan showing the water source
- f. Drainage requirements

## PINTAIL POINT Architectural Review Manual

The proposed Landscape and Irrigation Plan should be submitted to the Architectural Review Board for review and approval as soon as possible during the approval process, but in any event the plan must be approved prior to the completion of construction and then implemented in full within thirty (30) days after a Certificate of Occupancy is issued for your home.

Upon completion of the Landscape and irrigation Plan, the owner should notify the Architectural Review Board and a final inspection will then be made.

### 8. Future Improvement Review

Any modifications of existing improvements or construction of additional improvements must be with prior approval of the Architectural Review Board.

A request for review must contain the following:

- a. Site plan of proposed location of improvements
- b. Floor plan of intended improvements
- c. Letter with full description and purpose of improvements
- d. Material and color samples to be used
- e. Names and addresses of adjacent property owners

## III. SITE PLANNING GUIDELINES / MINIMUM DESIGN STANDARDS

### A. Building Setbacks

1. Typical building setbacks will be no less than the following minimum dimensions:  
Front.....40 feet  
Side.....10 feet  
Rear.....20 feet
2. On corner lots, the house may orient to either street.  
Front (both streets).....40 feet  
Side.....10 feet  
Rear.....20 feet
3. On Lots 9 - 28, special setbacks and a prescribed building area will be in place. Consult your plat for a description of those setbacks.

# PINTAIL POINT

## Architectural Review Manual

### B. Site Clearing

The lots in Pintail Point are wooded, covered with pines and oaks. In order to preserve the natural surroundings and maintain privacy between lots, every attempt should be made to protect areas of natural vegetation. Houses should be sited and planned in a manner that preserves trees when possible. Trees outside the building pad should be preserved and protected. Driveways and other site development construction should be planned to preserve trees and other natural site features.

### C. Site Grading

Any necessary grading should be kept to a minimum and should reflect a natural and gradual appearance. Grading shall not encroach upon the drip lines of trees to be preserved unless tree preservation techniques are utilized.

Retaining walls should be used to reduce areas which need grading and to preserve vegetation. The design and placement of such walls must reflect the architecture of the house and be well integrated into the site.

### D. Site Run Off

SCDHEC requires that silt fencing be used around all construction sites that drain to the street or adjacent properties to avoid erosion or run off from the lot during construction. Silt fencing must be installed by the builder and the Lot Owner prior to clearing and maintained in accordance with SCDHEC Regulations at all times during construction. Failure to do so may result in fines to the builder and Lot Owner up to \$50.00 per day, and 110% of cleanup cost and the builder and the Lot Owner shall pay to the Declarant all attorney's fees and cost incurred by Declarant and all fines paid by Declarant resulting from the builder or Lot Owner's failure to maintain the silt fences to avoid erosion or run off from the lot during construction in accordance with SCDHEC Regulations. Once final grading is completed for the driveway and landscaping is installed, the silt fencing can be removed.

### E. Construction Trash

All construction sites are to be kept clean of debris during construction of all homes in Pintail Point. It is the builder's and Lot Owner's responsibility to keep the debris picked up, contained, discarded or in an on-site dumpster. This is to avoid debris blowing onto neighboring sites or into the neighborhood. Unkept construction sites will be subject to a letter of warning for the first offense and a \$100 fine for subsequent offenses of excessive debris.

# PINTAIL POINT

## Architectural Review Manual

### F. Driveways and Garage Access

1. Driveways may have one or two street access points as desired or as the site permits.
2. A minimum of one off-street parking place per bedroom will be required. No overnight parking will be allowed on the subdivision streets.
3. Driveway edges will not be closer than three (3) feet to any property line.
4. Garage access must be from the side or the rear. (Not to include Lots 30-61)
5. Driveway slopes should not exceed 1:8. All driveway transitions between different slopes to be smooth.
6. Driveways must be concrete except as noted at item "7." Alternate driveway materials will be considered upon request.
7. On Lots 9 - 28, driveways shall be concrete from the street curb extending 30' into the site. The driveway may change to asphalt or crushed stone from that point to the house.

### G. Sidewalks

A 5' concrete sidewalk, 5'-0" in width, shall be constructed along the street at Lot 30 - Lot 110 as shown on the plat. The sidewalk shall extend from property line to property line and connect in alignment and smooth grade transition with the adjoining sidewalk.

### H. Landscaping

Pintail Point is a beautiful, heavily-wooded site, sloping to Lake Murray. All site development and landscaping should enhance the natural surroundings and features of the site and comply with the minimum landscaping standards found in the appendix.

1. The submitted landscape plan should include the entire lot, from the back of the curb at the street to the rear property line or lake edge.
2. The landscaping can consist of grassed lawn area and natural beds. All natural landscape beds must be clean of undergrowth, neat and easy to maintain with ground covering or mulch throughout the entire bed.
3. On the deep lots (Lots 9 - 28), natural growth areas are permitted. A landscaped, grass area should extend from the back of the curb at the street to a line 10' onto the lot (from the street right-of-way). A natural growth area can extend from this line to within 20' of the front of the house, at which point the landscaping should be developed as typically prescribed for the remainder of the lot. Unsightly undergrowth and vines, leaning and dead trees must be removed from the natural growth area.
4. The lake edge should be developed as a natural sloping bank.

## PINTAIL POINT Architectural Review Manual

5. The area between the street curb and house must be completely covered with an irrigation or sprinkler system.
6. All landscaping and irrigation work must be contracted to a licensed landscaping firm, unless prior written approval is given by the ARB.
7. The Owner accepts responsibility for maintenance of all landscaping.

### I. Signs

Signs on property will be limited to the following:

1. One project identification sign which will conform to the standard construction sign detail included in the Design Details Section of this manual.
2. One real estate for sale sign which will conform to the standard construction sign detail included in the Design Details Section of this manual.

### J. Walls and Fences

1. A site plan should be submitted indicating the full extent of all walls and fences, including gates and piers.
2. Privacy walls and decorative fences are permissible on the side and rear property lines, as noted below.
3. Walls and fences will not extend into the front yard beyond the front face of the structure.
4. On Lots 15 - 28, walls and fences on the side property lines shall not extend to the rear property line beyond the prescribed building area.
5. On Lots 9 - 28, a 6' high masonry or wood entry posts on each side of the driveway are permitted at a 15' setback from the front property line.
6. On Lots 9 - 28, a 4' high wrought iron (tubular aluminum, prefinished) or wood gate is permitted across the driveway at a 15' setback from the front property line.
7. All wood fencing shall be treated or finished with a natural stain on both sides. A sample of the stain must be submitted for approval.
8. The face of the masonry columns and walls should match the masonry (brick or stucco) of the house.
9. All gates should be compatible with the design of the adjoining fence.
10. The maximum height of all fences/walls will be 6'0".
11. Samples designs of walls and fences have been included in the design details section.

## PINTAIL POINT Architectural Review Manual

<sup>12.</sup> Walls and fences are not limited to the designs shown, but should be well-designed, sturdy, finished to both sides, easy to maintain, constructed in the following materials:

wood (treated or cedar)  
wrought-iron (prefinished tubular aluminum)  
brick  
stucco

13. The Owner accepts the responsibility for maintenance of the fence.

### K. Decks / Docks

On Lots 15 - 29, wood decks / docks are permitted along the lake (as permitted by Lexington County and SCE&G). However, no construction over 18” above the existing grade will be constructed beyond the prescribed building area toward the rear property line. Decks and docks should be finished with natural color semitransparent stain only.

### L. HVAC Condenser Units

HVAC condenser units and other house-related equipment should be placed in a location that is not obtrusive to neighbors. The equipment should be screened with landscaping or a low decorative fence.

### M. Satellite Dishes

Freestanding satellite dishes are not permitted; antenna, freestanding or mounted on the structure, are not permitted. Television satellite receivers are permitted and limited to no larger than 24” in diameter. Television satellite receivers must be installed in the rear of the property and hidden from general view. Exceptions must be submitted to the ARB.

### N. Mailbox Posts

Mailbox posts will be of a uniform-design type. Details for the standard mailbox post have been included in the design details section.

### O. Site Lighting

Lighting should be provided for a safe approach to the residence and for proper illumination of landscape features, docks, and patios. Light sources should be concealed and light levels kept to a minimum so as not to create a nuisance for neighboring properties.

## IV. HOUSE PLANNING DESIGN GUIDELINES / MINIMUM DESIGN STANDARDS

### A. Size

1. The minimum size of the primary structure is to be 2,200 square feet. This is to be calculated as the enclosed heated area and not to include unfinished areas, garages, or accessory structures.

## PINTAIL POINT

### Architectural Review Manual

2. The maximum size of the primary structure is to be 5,000 square feet. This is to be calculated as the enclosed heated area and not to include unfinished attics (constructed in a typical fashion) and garages.
3. All area calculations should be to the outside of the perimeter stud wall.
4. On Lots 1 - 3 and 8 - 28, dependency structures are permitted in addition to the primary structure.. (Maximum 2 dependencies, ex.studio, guesthouse, poolhouse. A detached garage counts as one dependency.) The maximum square footage (total cumulative) of all dependencies is 1,200 in addition to the primary structure. All structures shall be within the prescribed building area.
5. In order to maximize the lake view from interior lots, the construction height on lake lots will be restricted. On Lots 15 - 29, the maximum permitted height is limited to two stories above grade and to 35' from the average grade at the house perimeter to the average roof height (median height of eave and highest roof point).

#### B. Foundations

1. Conventional crawl space foundations are encouraged. Slab-type foundations are required to be of the perimeter-wall type with the slab being no closer to the finish grade than 1'-6".
2. Foundation vents, when used as a design feature, are required to be centered under the window above or to be placed symmetrically in the building mass.
3. The house should be placed and the site contoured to minimize the foundation wall height.

#### C. Foundations of 5' or more in height

1. Special attention and review will be given to any house with an exposed foundation of 5' or more in height.
2. Design care should be given to break up the mass and uninterrupted run of high foundations.
3. On houses of exposed foundation of 5' or more in height, documentation must be provided to clearly demonstrate grades, porches, rails, lower level plan, steps, etc.

## PINTAIL POINT

### Architectural Review Manual

5. On the front stair to any porch 5' or more above grade:
  - a. Minimum stair width 7'
  - b. Unless otherwise approved by the ARB, a maximum of 7 risers in a straight run without a landing and/or turn (45° or 90°) in the stairs.
  - c. Use terraces, retaining walls, raised planters to reduce stair height and to create a natural landing and/or platform for the stairs

#### D. Exterior Walls

1. Wall Height:

Floor to ceiling heights on all levels except those occurring in attic rooms are to be a minimum of 9'-0".

2. Materials:

Traditional exterior finish materials of brick, stucco, stone, wood siding and wood shingles are encouraged.

- a. Bricks are to be natural earth tone colors. White and yellow bricks are not acceptable.
- b. Stucco color and texture will be evaluated for neighborhood compatibility.
- c. Wood siding to be solid stock varieties. Hardi-plank siding is permitted. Synthetic wood substitutes and wood composite materials for siding and trim will be considered. Plywood siding, vinyl and aluminum sidings are not permitted.

3. Combination of Materials:

A mix of compatible materials (ex. brick and wood siding) is encouraged, with careful attention to the juncture of materials:

- a. At a vertical juncture of different materials, the change of material is to occur as a change of plane only - a change of material should not occur at an outside corner.
- d. At a horizontal juncture of different materials, if the top material (wood siding, wood shingles) is in the forward plane, use a band board along the lower edge of the top material. If the lower material (masonry, stucco) is in the forward plane, use a cap or water table along the top edge of the lower (base) material.

#### E. Windows

1. Type:

Windows can be wood, vinyl or fiberglass. Double-hung is preferable. Single-hung is acceptable. Awning windows and horizontal sliding windows will be acceptable on sunroom applications only.

## PINTAIL POINT

### Architectural Review Manual

#### 2. Placement:

The windows should be placed in a traditional fashion with the head height being approximately 7'-6" to 8'-0" above the floor. The clearance between the top floor window head and the bottom member of the cornice (frieze board) should generally be approximately 12". See design detail section.

#### 3. Proportion and Shape:

Window placement and proportion are important to the overall composition and the windows will be carefully reviewed. Windows should be 2:1 ratio height to width. Square or round windows will be considered as accent elements.

#### 4. Shutters:

Windows shutters are a traditional element adding interest to a design. Shutters must appear functional and be proportional to the adjacent window.

### F. Cornices

#### 1. Overhangs:

Cornice overhangs should generally be a minimum of 12". Other designs will be evaluated based on the individual design application.

#### 2. Design Types:

Three traditional cornice configurations are acceptable as appropriate to the house style and are described in the design details.

a. Traditional flat cornice - Flat eave with crown mould or ogee gutter and returns on gable ends. Returns must have standing-seam metal roof.

b. Sloping eave - Sloping eave on bottom of rafters and square edge trim. Gutters, if used, should be half-round.

c. Open eave, exposed rafter tails - Square edge trim (minimum 2½" edge trim) on the end of the sheathing and the rafter. Exposed projecting roof shingle nails are unacceptable. Gutters, if used, should be half-round.

#### 3. Materials:

a. Cornices are to be built of wood or composition components.

b. Cornices built of aluminum or vinyl will be considered. Accurate details of the components must be supplied for review. The profiles and dimensions of the aluminum/vinyl cornices must approximate the typical design details shown.

# PINTAIL POINT

## Architectural Review Manual

### G. Roof

#### 1. Slope:

Minimum slope will be 9/12 on the major roof forms. Other slopes may be considered for specific design applications.

#### 2. Roof Materials:

- a. Fiberglass Shingles - Architectural grade - 30 year minimum
- b. Standing Seam Metal

3. Smaller roof sections on appendages to main body of the house (porches, bays, projections) may be lower slope than the main body roof and should be standing-seam metal. All roof surfaces lower than 4/12 slope or less than 4' in one direction (including gable returns) should be standing-seam metal.

#### 4. Flashing:

All exposed flashing will be either copper, pre-finished aluminum, or painted aluminum. (The flashing material must be compatible with adjacent metal roof material.) All brick chimneys and side wall flashing will be step-flashed and counter-flashed.

#### 5. Roof Penetrations:

All plumbing vents, attic vents, and other necessary roof-mounted devices should be placed on the rear slopes away from the street view.

### H. Porches

A variety of porch types will be evaluated and accepted based on the individual design application. All front porch columns must be a minimum 10" width.

Minimum porch detail standards are included in the design detail section. See porch foundation requirements under "Foundation".

### I. Chimneys

1. All chimney/flues are to be enclosed in construction and material, with finishes, to match the house construction.
2. All masonry chimneys are to continue above the roof per code with the chimney top as shown in the Design Details section. If the chimney is to have a cap, the cap design should be submitted with the elevation drawings for approval.
3. On all prefabricated fireplaces, the flue should be enclosed for the full height with a metal shroud on the prefabricated flue cap as shown in the Design Details section.
4. On all ventless fireplaces, the fireplace enclosure should be constructed in the wall finish material to the underside of the eave.

# PINTAIL POINT

## Architectural Review Manual

### J. Accessory Structures

#### 1. Garages:

Minimum two-car Garages are required, either attached or detached.

- a. Garage doors should not face the street except on lots 30-61 where lots are narrower.
- b. All street facing garage doors should be individual doors, maximum width 10'-0", and all doors should be the same size. Other doors can be double width.
- c. Lintels over the garage doors should be a minimum 8" high (brick soldier course, built-up wood trim with drip cap, stucco projection).

#### 2. Sheds and Other Accessory Structures:

Sheds and other accessory structures can be placed on the property, but they will be subject to all of the standard and special setback requirements that may apply. The design should be compatible with the design of the primary structure and should in no way detract from the character of the neighborhood.

#### 3. Pools and Pool Houses:

Pools and pool houses will be evaluated and approved based on the individual design application.

# APPENDIX

## **PINTAIL POINT SUBDIVISION MINIMUM PROFESSIONAL LANDSCAPE REQUIREMENTS**

- \* Irrigation systems for all front and side yards are required. Systems covering all landscaped areas are strongly encouraged. Sprinkler heads at curb should be protected and should not spray across sidewalk/into road during normal operation.
  
- \* Sod is required for all front/side yards. Back yards and all disturbed areas within 30 feet of the house must be either sodded or overseeded with seasonal turf (winter rye/brown-top millet) for erosion control.
  
- \* Natural areas up to 30% of the prescriptive area are allowed. Bare ground and/or unplanted/mulched hillsides are prohibited.
  
- \* Foundation shrubs as follows:
  - Back row.....7gallon shrubs minimum (no less than 12)
  - 2<sup>nd</sup> Row/Accent.....Combination of 3gal/1gal shrubs (no less than 24)
  - Corner/Anchor.....15gallon or larger (no less than 4)
  - Specimen/Anchor.....25gallon or larger (no less than 2)

*Note: The Pintail Point Architectural Review Board reserves the right to increase these minimum requirements for specific plans, particularly those with foundations of heights greater than 6 feet. Shrubs can be no less than 3 feet below front windows.*

- \* All landscaped areas must be mulched.
  
- \* Landscape lighting is allowed and encouraged. It should not illuminate areas outside your yard.

A landscaping detail of your home must be submitted a minimum of thirty (30) days prior to occupancy. Suggestions may be made to you based upon the minimum requirements as outlined above. In all cases, these standards are intended to ensure the level of excellence in your neighborhood, and to assist you in the beautification of your home. These requirements are not intended to limit the scope of your resources and/or creativity, but rather to assure that proper and minimum sizing, spacing and taste apply.

**IMPORTANT**...All aspects of your basic landscaping plan, as approved by the Pintail Point Subdivision Architectural Review Board, must be completed no later than thirty (30) days after a Certificate of Occupancy is issued for your home.



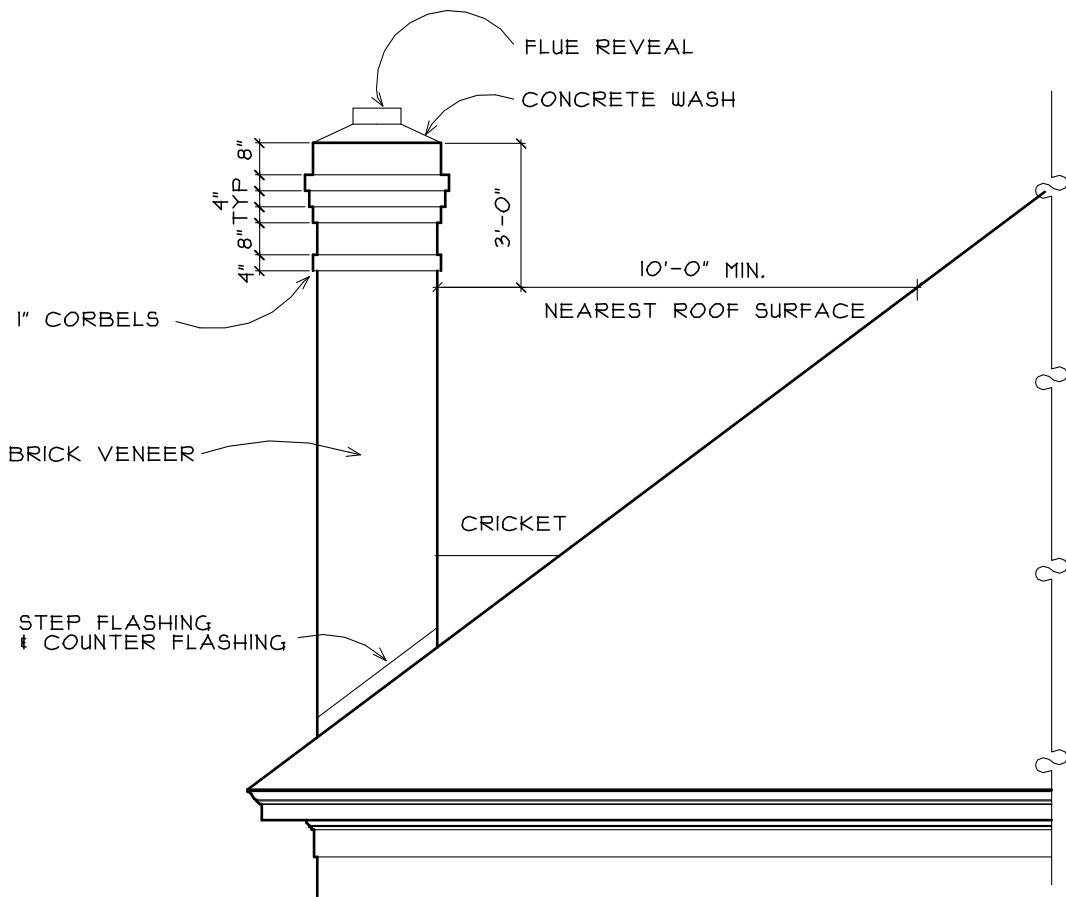

BRICK VENEER CHIMNEY DETAIL

1/4" = 1'-0"

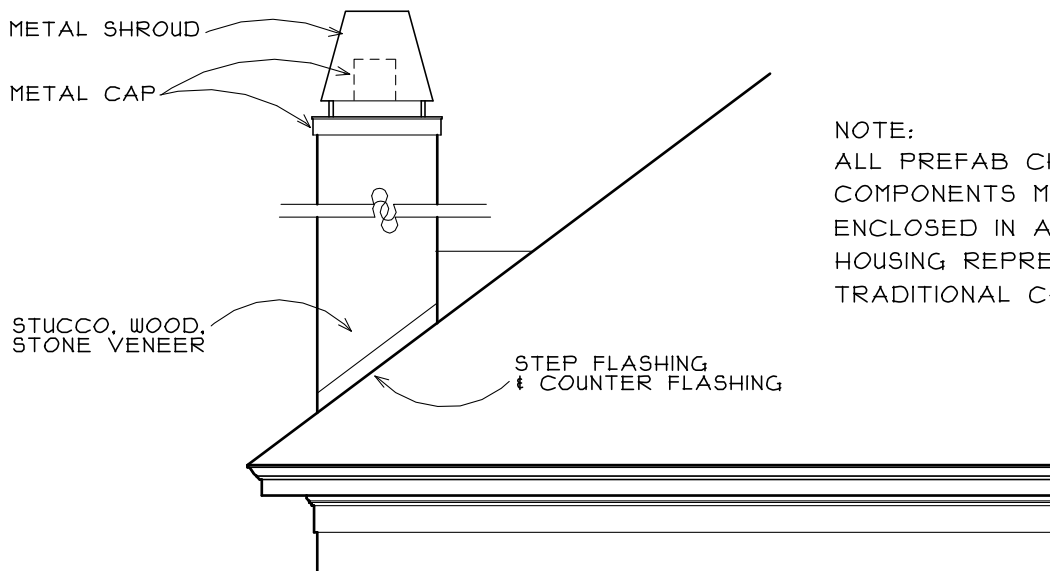

ADDITIONAL CHIMNEY MATERIALS DETAIL

1/4" = 1'-0"

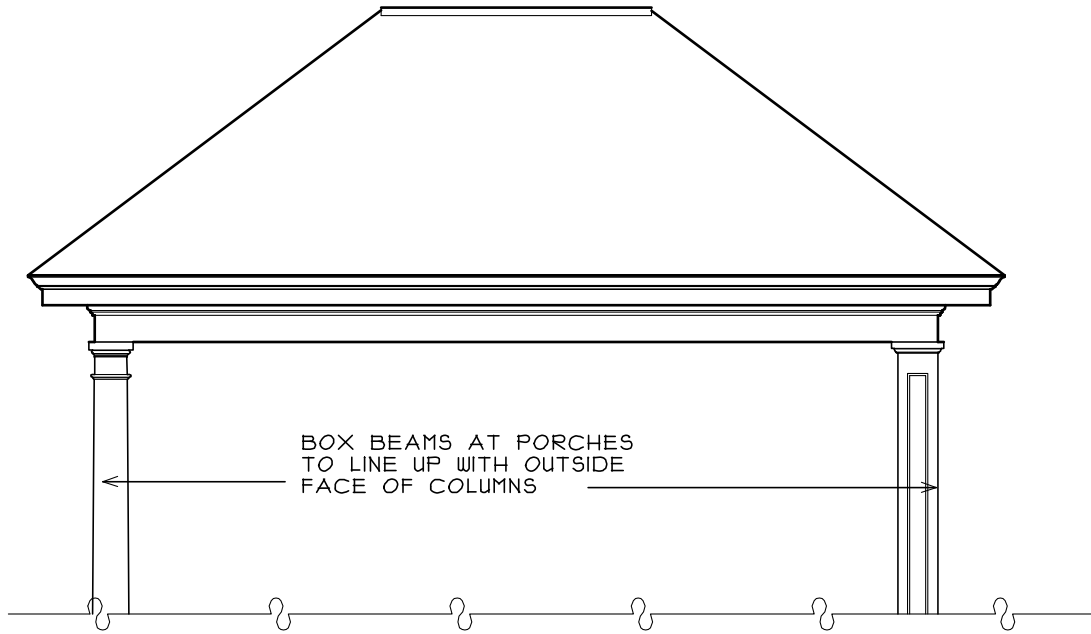

COLUMN DETAIL AT PORCH

1/4" = 1'-0"

NOTE: ALL PORCH COLUMNS TO BE 10" MINIMUM

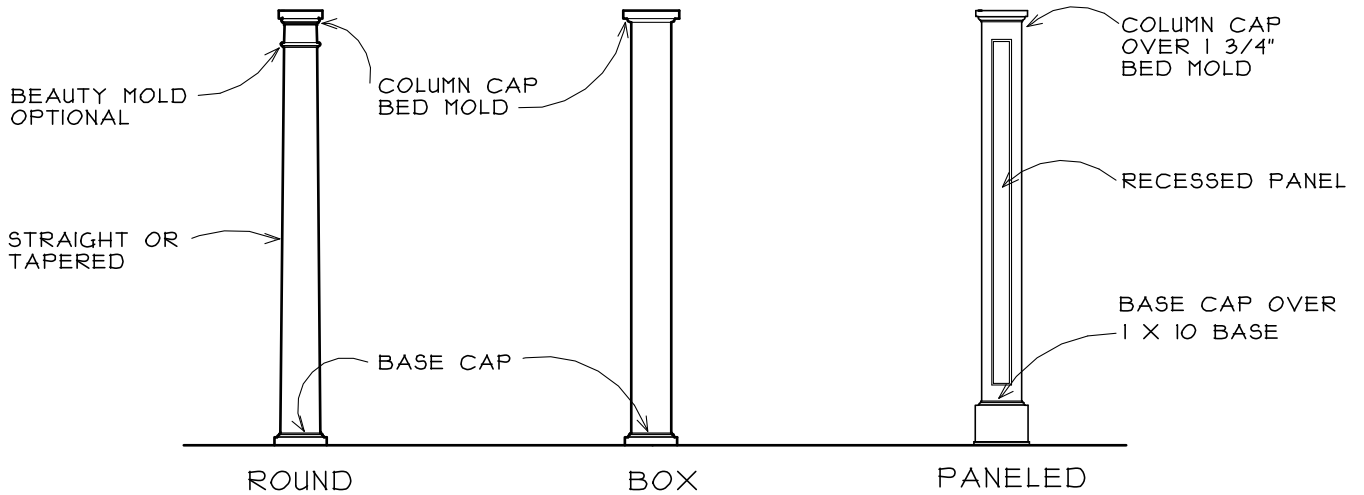

COLUMN ELEVATIONS

1/4" = 1'-0"

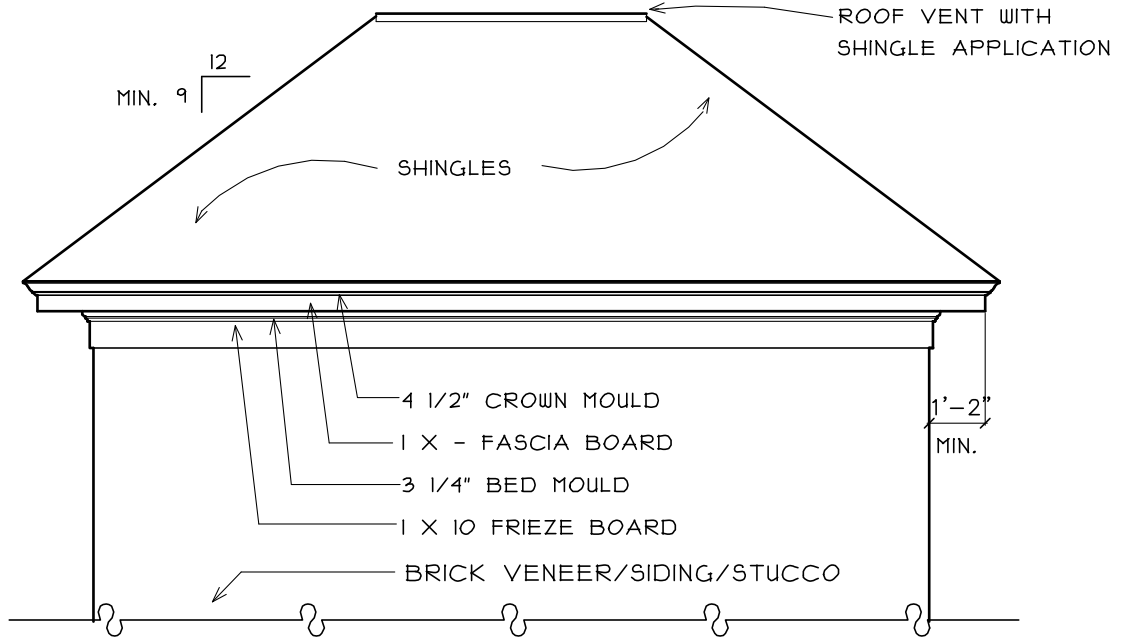

TYPICAL DETAIL AT HIP ROOF

1/4" = 1'-0"

NOTE: NO COMPOUND PITCHES

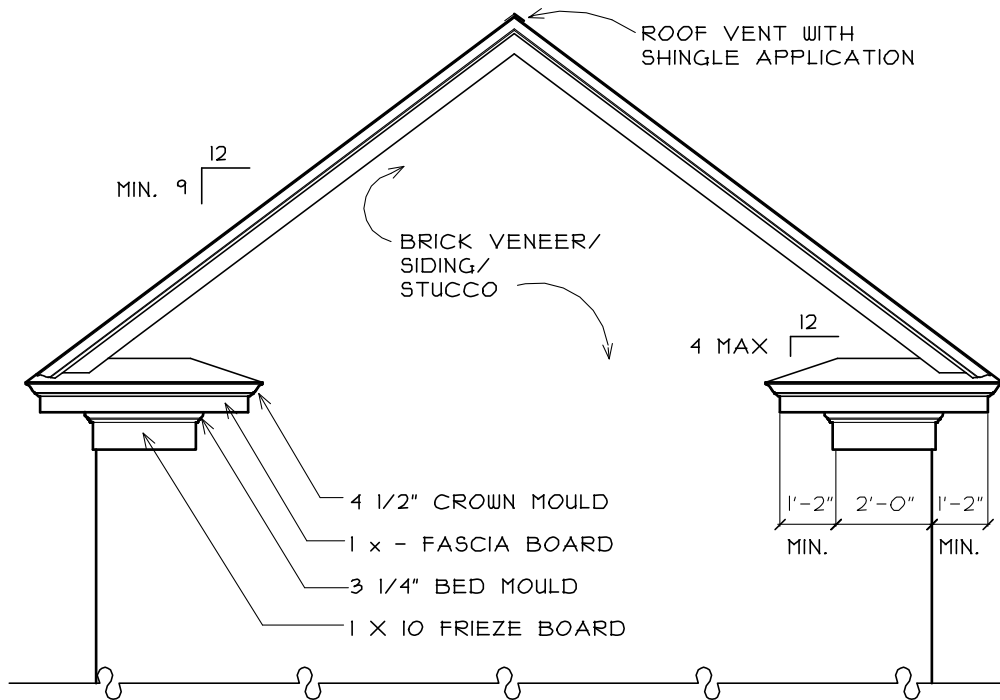

TYPICAL DETAIL AT GABLE ROOF

1/4" = 1'-0"

NOTE: NO COMPOUND PITCHES

NOTE: NO COMPOUND PITCHES

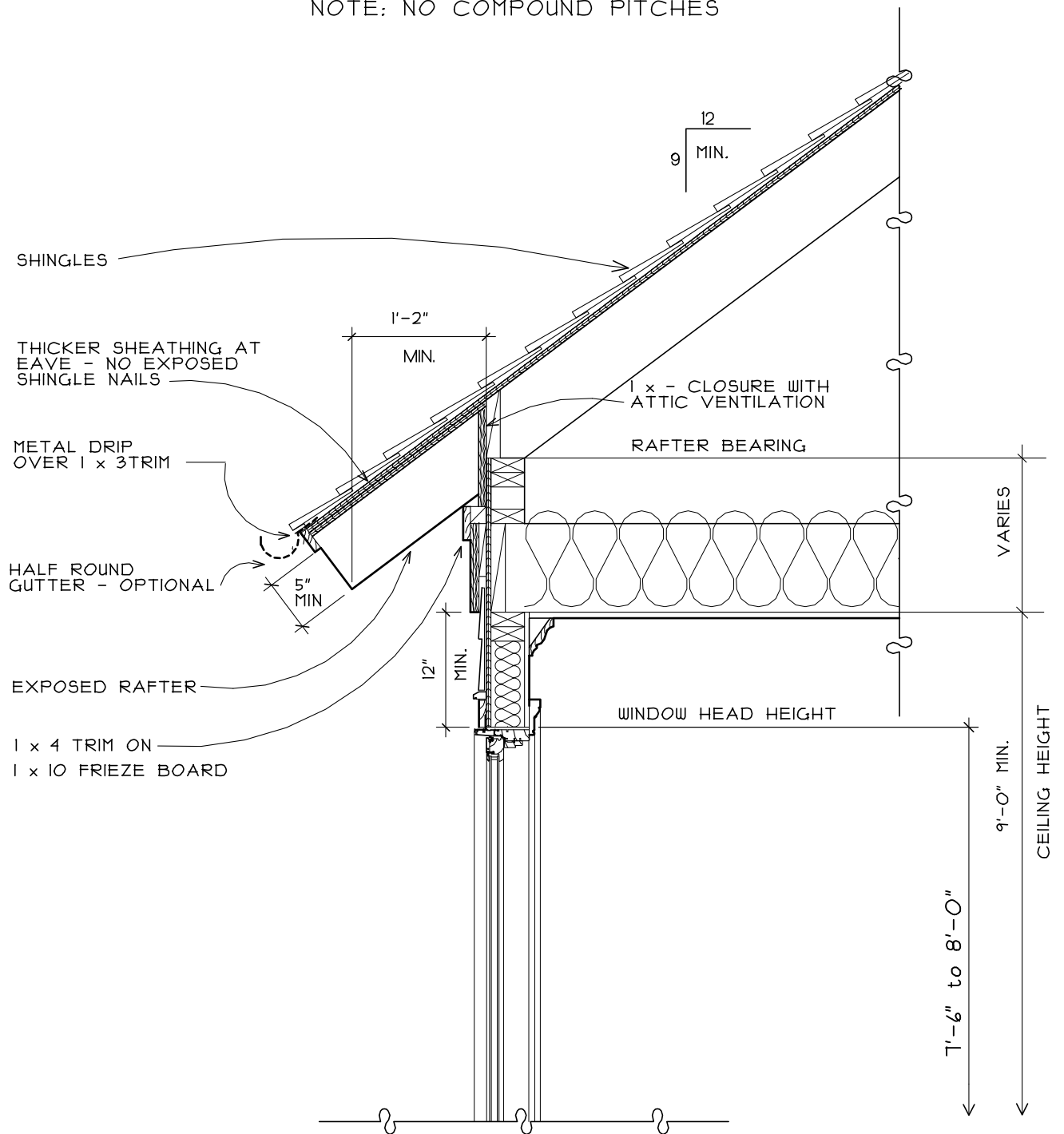

### EXPOSED EAVE DETAIL

3/4" = 1'-0"

NOTE: NO COMPOUND PITCHES

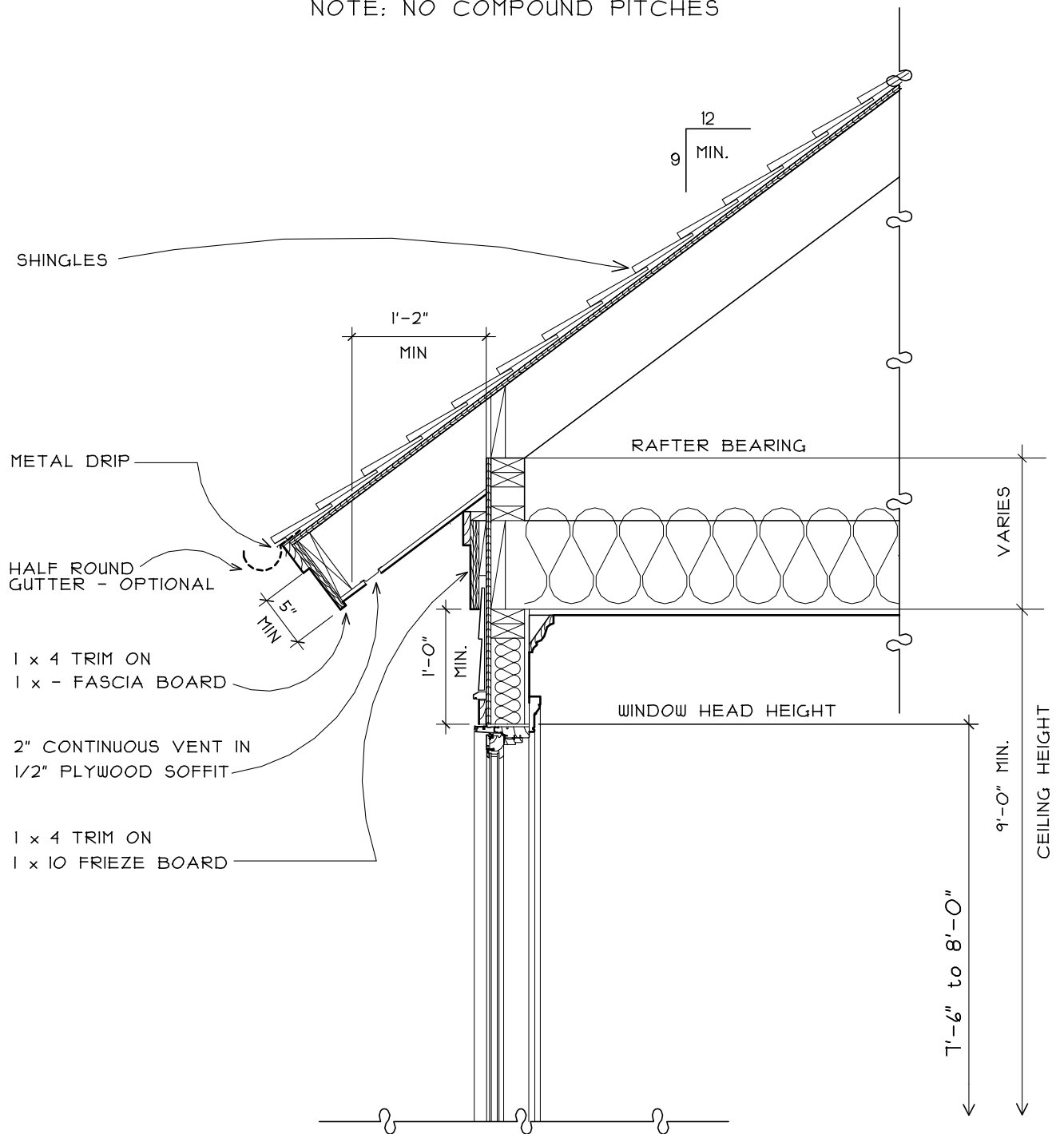

### SLOPED EAVE DETAIL

3/4" = 1'-0"

NOTE: NO COMPOUND PITCHES

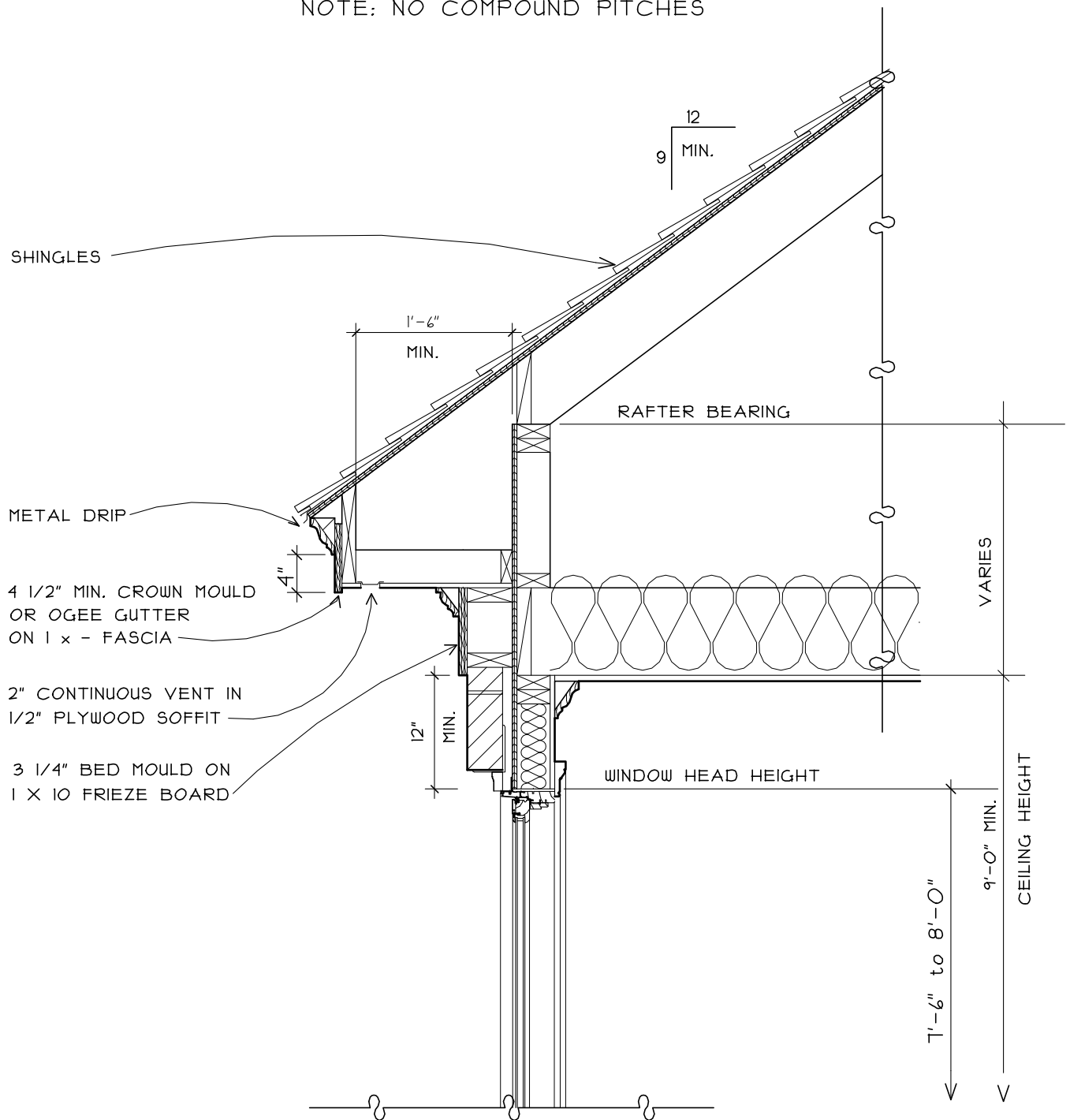

TYPICAL BRICK VENEER EAVE DETAIL

NOTE: NO COMPOUND PITCHES

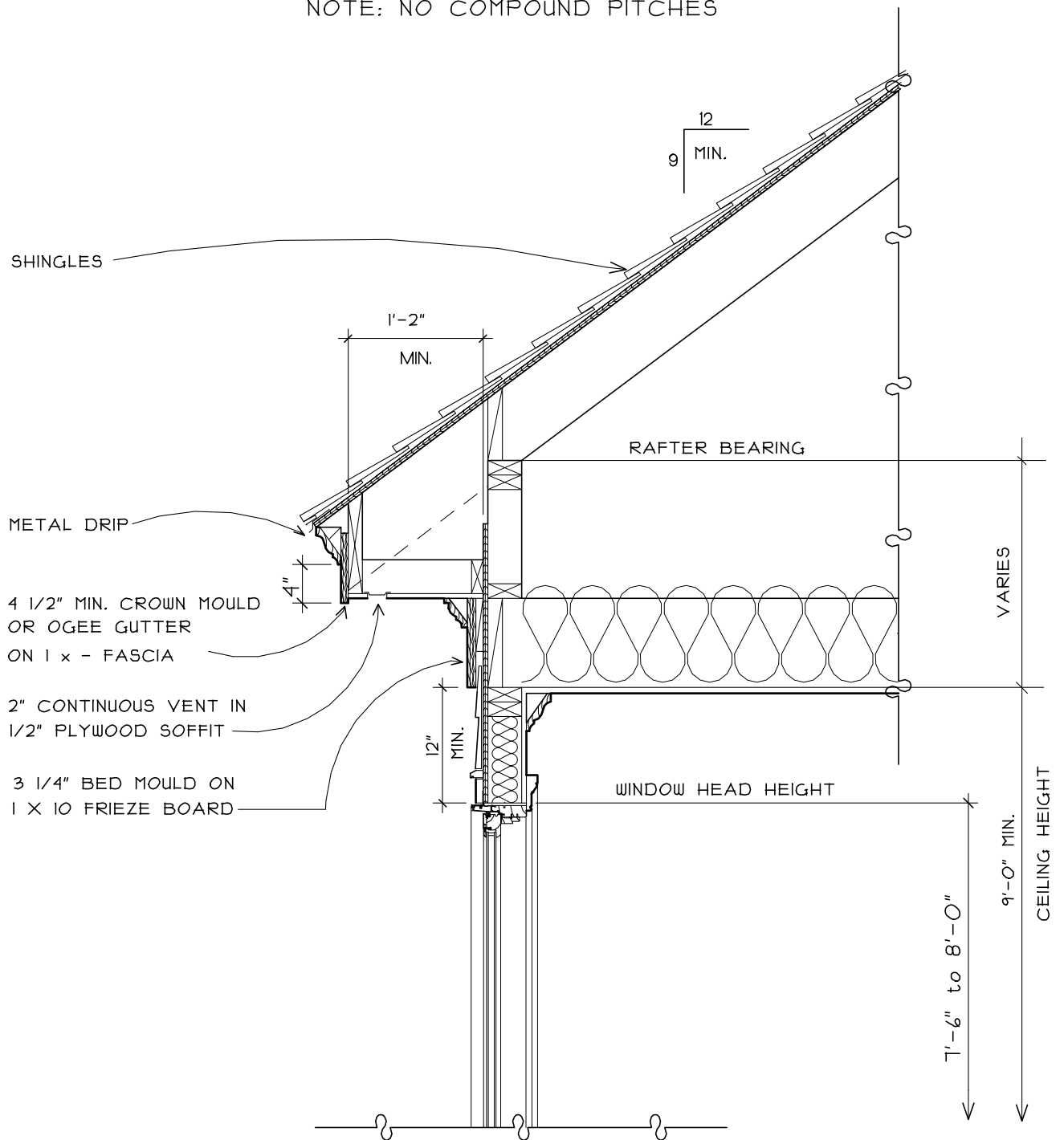

TYPICAL EAVE DETAIL

3/4" = 1'-0"

PINTAIL POINT - FENCE DETAILS

NOTE: BRICK PIERS ALSO REQUIRED AT ALL LOT CORNERS AND GATE OPENINGS.

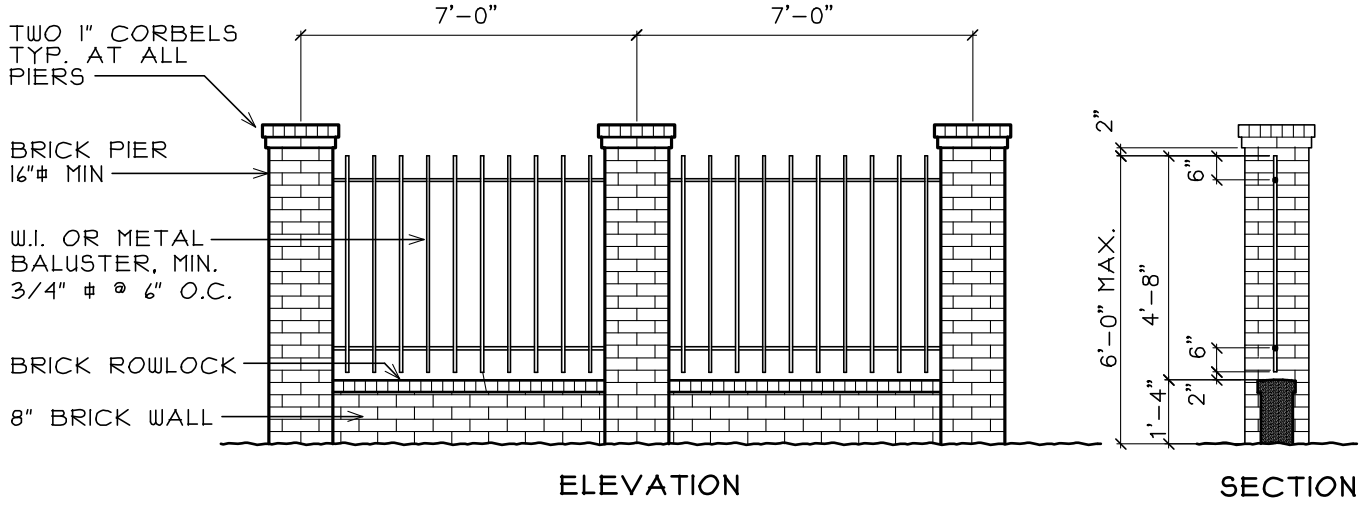

FENCE STYLE #2

1/4" = 1'-0"

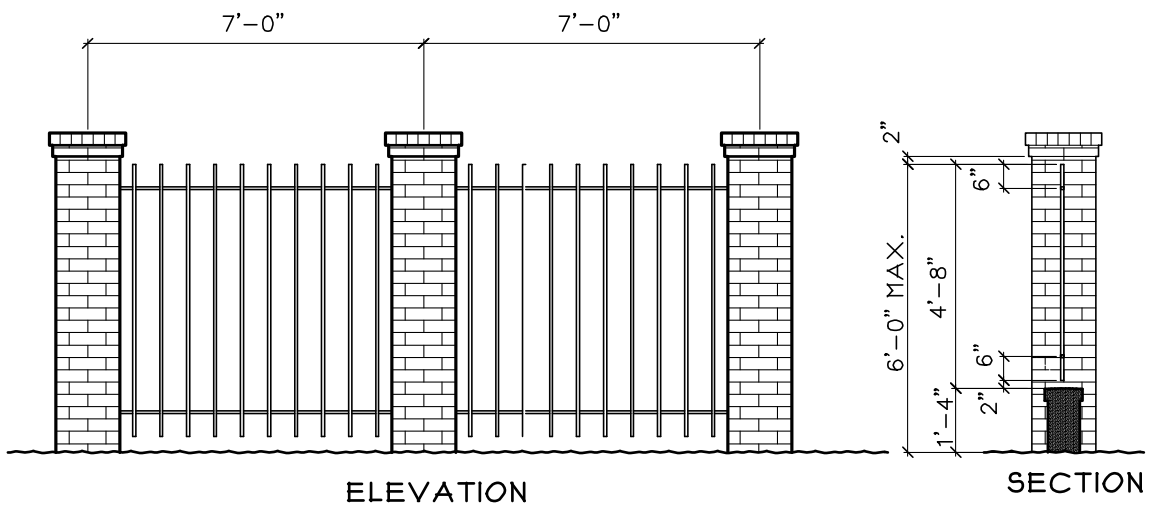

FENCE STYLE #2A

1/4" = 1'-0"

ALL NOTES AT STYLE #2 APPLY TO THIS STYLE

NOTE: BRICK PIERS ALSO REQUIRED AT ALL LOT CORNERS AND GATE OPENINGS.

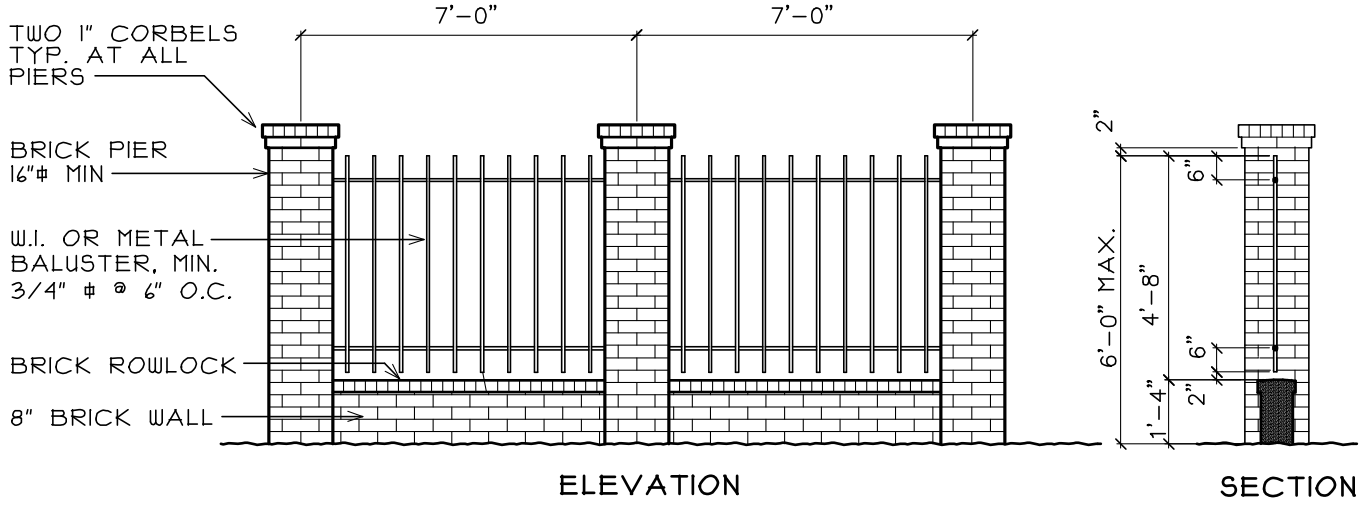

FENCE STYLE #2

1/4" = 1'-0"

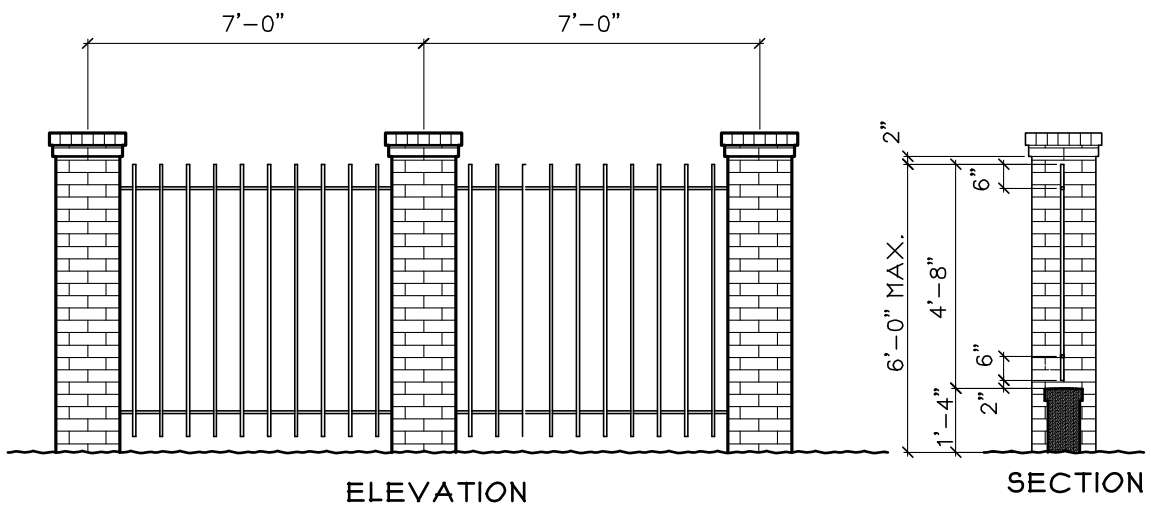

FENCE STYLE #2A

1/4" = 1'-0"

ALL NOTES AT STYLE #2 APPLY TO THIS STYLE

NOTE: BRICK PIERS ALSO REQUIRED AT ALL LOT CORNERS AND GATE OPENINGS.

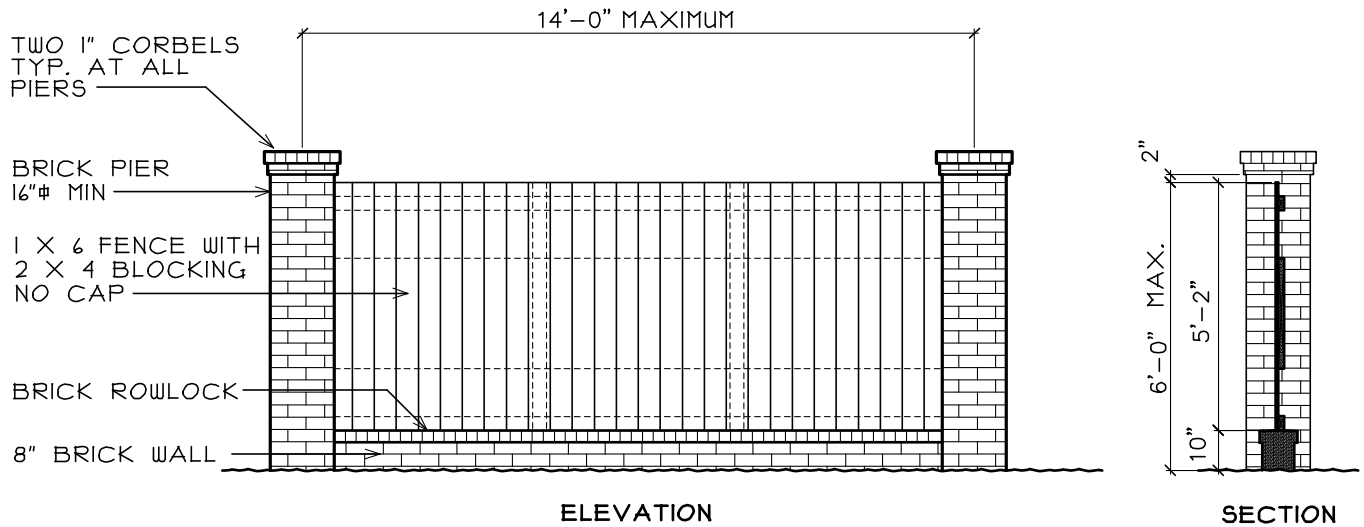

### FENCE STYLE #3

1/4" = 1'-0"

ADDITIONAL SUPPORTS REQUIRED BETWEEN PIERS TO PREVENT SAGGING. SUPPORTS TO BE PLACED ON BACK SIDE OF FENCE.

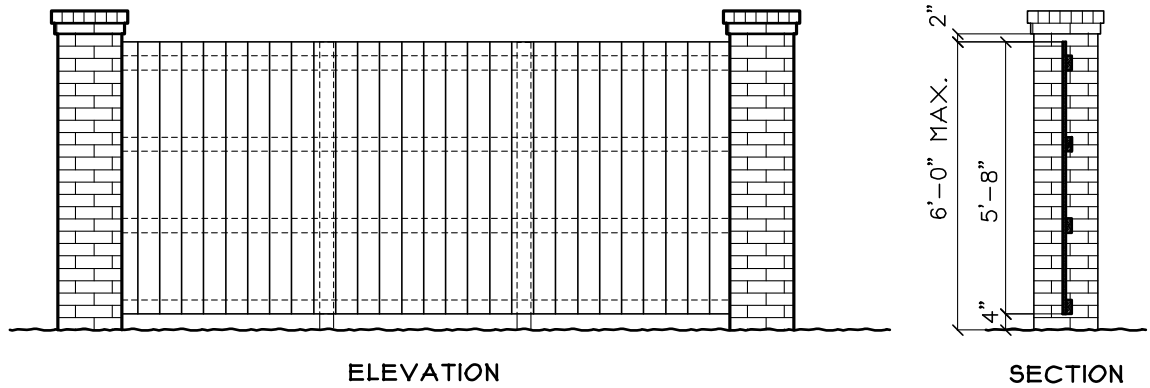

### FENCE STYLE #3A

1/4" = 1'-0"

ALL NOTES AT STYLE #3 APPLY TO THIS STYLE

NOTE: BRICK PIERS ALSO REQUIRED AT ALL LOT CORNERS AND GATE OPENINGS.

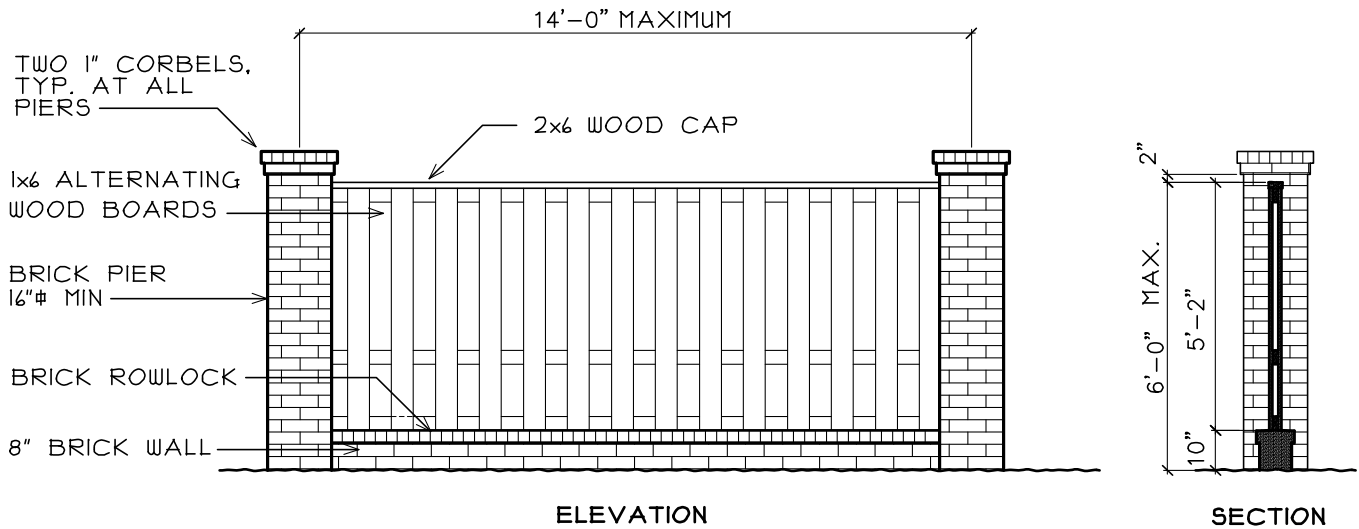

### FENCE STYLE #4

1/4" = 1'-0"

ADDITIONAL SUPPORTS REQUIRED BETWEEN PIERS TO PREVENT SAGGING. SUPPORTS TO BE PLACED ON BACK SIDE OF FENCE.

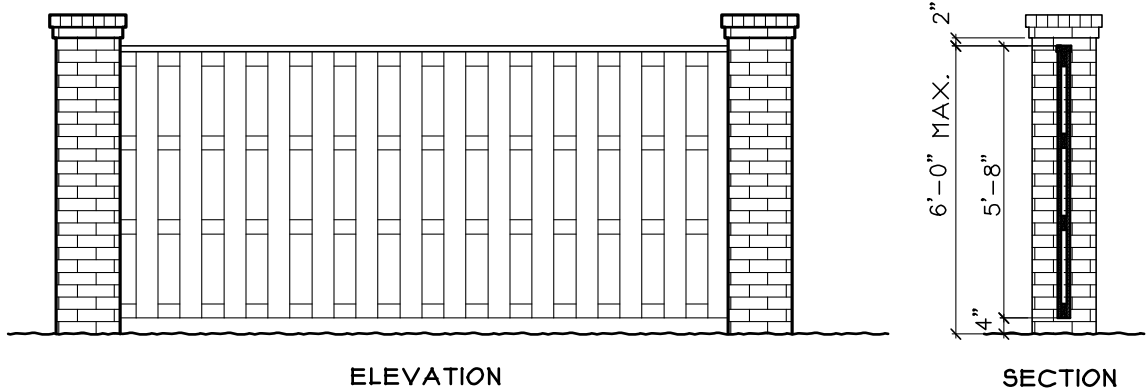

### FENCE STYLE #4A

1/4" = 1'-0"

ALL NOTES AT STYLE #4 APPLY TO THIS STYLE

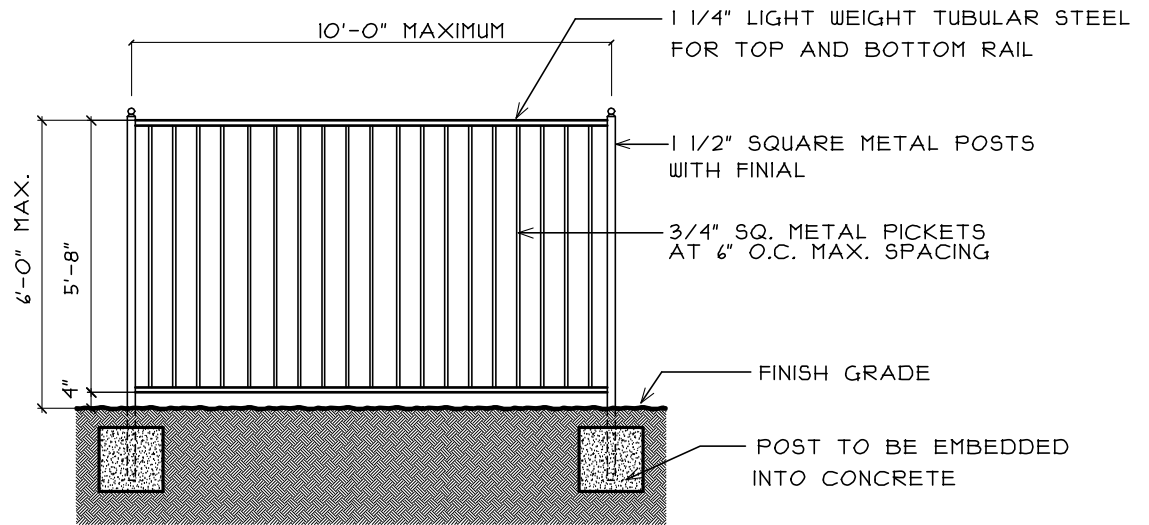

### FENCE STYLE #5

1/4" = 1'-0"

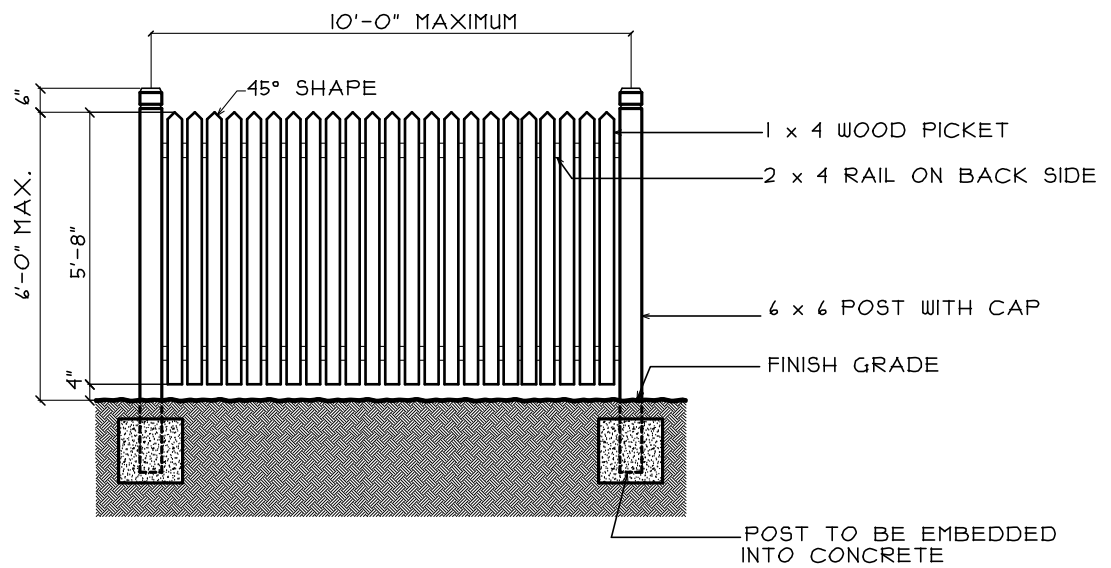

### FENCE STYLE #6

1/4" = 1'-0"

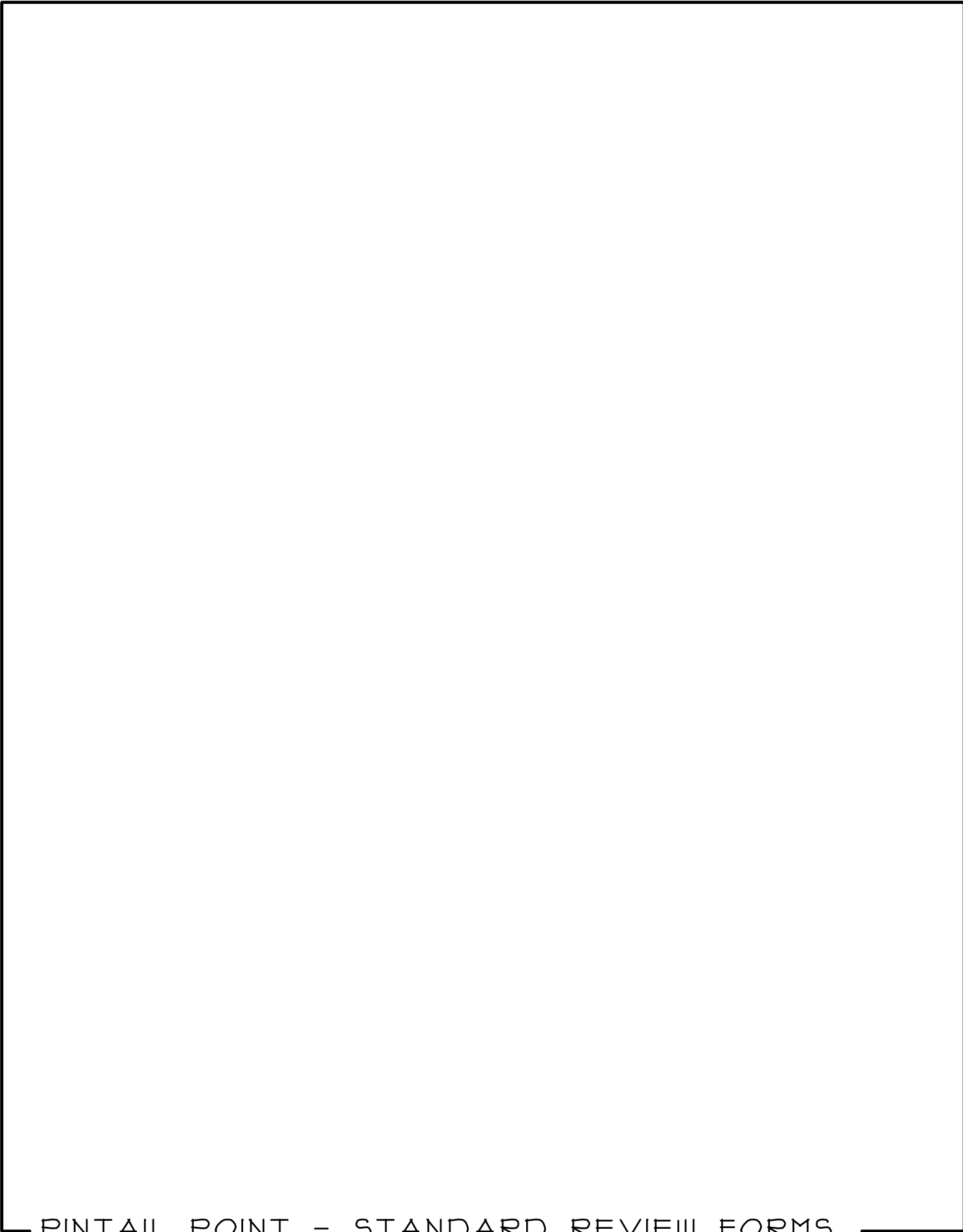

**PINTAIL POINT  
ARCHITECTURAL REVIEW BOARD  
Application for Design Review**

DATE: \_\_\_\_\_

OWNER'S NAME: \_\_\_\_\_

ADDRESS: \_\_\_\_\_

LOT #: \_\_\_\_\_

New home construction in Pintail Point is subject to strict architectural control. Prior to the clearing of the lot, the overall plan for construction must be approved by the Architectural Review Board (ARB).

Information needed, as well as certain minimum standards, are outlined in the following pages and in the Architectural Review Board Manual. Your submission package should be reviewed against the enclosed checklist; please attach the checklist to your submission.

Your request should be submitted by you or your representative to:

Pintail Point  
Architectural Review Board  
c/o Molten/Lamar Architects  
808-C Lady Street  
Columbia, South Carolina 29201  
Phone: (803) 799-7495

If changes are required, they will be noted on your plans. A copy of the plans, along with a letter outlining the changes, will be returned to you. **ALL PLANS SUBMITTED WILL BE RETAINED IN THIS OFFICE.** Changes required must be incorporated on the plans before being resubmitted.

If there are no changes required, the Control Checklist will be signed and returned to you. Construction cannot commence until the plans have received final approval.

The submitted plans must be clear, at a proper scale, and in enough detail to illustrate the design and to demonstrate that the prescribed guidelines have been met. It is the opinion of the ARB that an architect or qualified draftsman can best produce the required plans.

**PINTAIL POINT  
ARCHITECTURAL REVIEW BOARD  
Application for Design Review**

SCOPE: The purpose of this checklist is to provide the Architectural Review Board with accurate information concerning proposed construction within the subdivision. (Review the Architectural Review Board Manual for the full requirements.) The following items must be submitted for approval as appropriate for the project scope:

1. TREE SURVEY: Including site plan depicting any trees and all dogwoods, that are 6" in caliber at 4' in height.

\_\_\_\_\_ **Tree survey**                      **APPROVED / DISAPPROVED / PENDING**

2. SITE PLAN: (1" = 20' scale) Indicating proper building setback, walks, decks, driveways, outbuildings, etc. Site plan should denote the four corner elevations of the lot.

\_\_\_\_\_ **Site plan**                              **APPROVED / DISAPPROVED / PENDING**

3. FLOOR PLANS: (1/4" = 1'-0" scale) Indicating general floor plan layouts, heated and gross square footage, porches, stoops, etc.

\_\_\_\_\_ **Floor plan**                              **APPROVED / DISAPPROVED / PENDING**

4. ELEVATIONS: (1/4" = 1'-0" scale) Depicting exterior design, material designations, roof pitches, column sizes, cornice details, roof jacks, etc. with appropriate dimensions and notes for front, rear, and sides. (See Architectural Review Board Manual.)

\_\_\_\_\_ **Elevations**                              **APPROVED / DISAPPROVED / PENDING**

5. WALL SECTIONS: (3/4" = 1'-0" scale) Showing window header heights, elevation details, cornice details, roof jacks, etc. with appropriate dimensions and notes. (See Architectural Review Board Manual.)

\_\_\_\_\_ **Wall Sections**                              **APPROVED / DISAPPROVED / PENDING**

6. ROOF PLAN: Illustrating plan view roof design.

\_\_\_\_\_ **Roof Plan**                                      **APPROVED / DISAPPROVED / PENDING**

**PINTAIL POINT  
ARCHITECTURAL REVIEW BOARD  
Application for Design Review**

7. EXTERIOR COLOR SCHEME: Providing proposed colors for exterior wall finish, trim, shingles, shutters, etc. Samples may be required.

\_\_\_\_\_ **Color Scheme**      **APPROVED / DISAPPROVED / PENDING**

8. LANDSCAPE PLAN: Including site plan noting adult plant materials, sodded areas, natural areas, trees, etc. The landscape plan may be submitted before or during construction but must be approved prior to the completion of construction and implemented within three months after the completion of construction.

\_\_\_\_\_ **Landscape plan**      **APPROVED / DISAPPROVED / PENDING**

9. CONDITIONS AND COMMENTS: See Attached Sheet.

**THE SUBMITTED PLANS ARE:**

**A. Preliminary Approval:**

**APPROVED** \_\_\_\_\_ **DISAPPROVED** \_\_\_\_\_ **PENDING\*** \_\_\_\_\_

**B. Final Approval:**

**APPROVED** \_\_\_\_\_ **DISAPPROVED** \_\_\_\_\_

\_\_\_\_\_  
Date

\_\_\_\_\_  
For the ARB

\* See attached page for comments.

*NOTE: The Architectural Review Board reserves the right to amend these guidelines when deemed necessary.*

**PINTAIL POINT  
ARCHITECTURAL REVIEW BOARD  
Application for Design Review**

**COMMENTS:**